

PE SERIES

LED Bar Display Pressure Sensor

DP5/DPH
Head-separated

DP4

DP2

DP3

DP-M

PE
LED Bar Display

Digital Display



Mechanical pressure switches are outdated choose the contemporary pressure sensor with LED bar display



Bright LED bar display

It is easy to read the measured pressure level as the bright red LEDs light up successively with change in the applied pressure.
(Display resolution: 2.5 % F.S.)

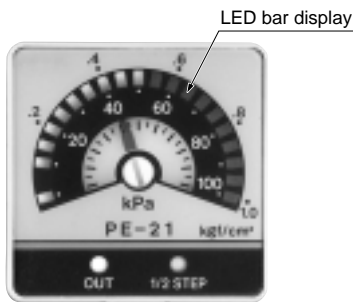

Simple pressure level setting

As the pressure setting is done directly on the dial, it can be done easily and quickly according to the operating conditions.

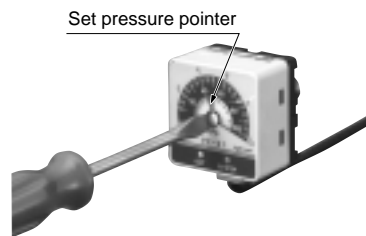

Rotating the set pressure adjuster, turns the pointer simultaneously. The value indicated by the pointer represents the set pressure level.

Reliable and durable

Mechanical pressure switches easily breakdown if the pressure fluctuates excessively. The diffused semiconductor transducer used in the PE series makes it reliable and durable.

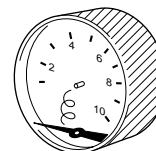

Mechanical pressure switch

Panel mounting bracket

A panel mounting bracket is available for panel mounting.

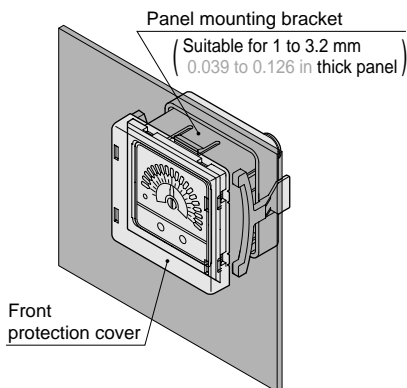

Sub-scale

The PE series incorporates an additional sub-scale which allows reading of the pressure level in kgf/cm² or cmHg.



Wide variety

Models suitable for use in different parts of the world are available. Care has been taken regarding the pressure unit, output mode and pressure port used in different places.

	Pressure unit (Sub-scale)	Output mode	Pressure port
Asian	kgf/cm ² (Positive pressure) cmHg (Vacuum pressure)	NPN	R ¹ / ₄ male thread and M5 female thread
North American	psi	NPN	NPT ¹ / ₄ male thread and 10-32UNF female thread
European	bar	PNP	G ¹ / ₈ male thread and M5 female thread

APPLICATIONS

Measuring pressure of compressor

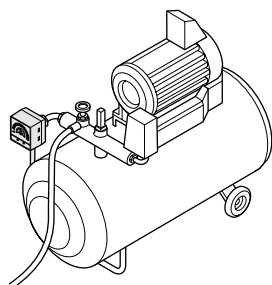

Measuring pressure applied to dispenser

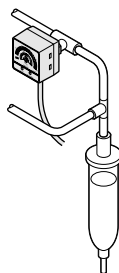

Confirming suction of workpieces

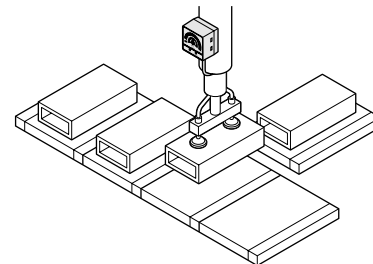

ORDER GUIDE

Type			Appearance	Rated pressure range	Model No.	Pressure port	Output
Vacuum pressure	- 101 kPa type	Asian		0 to - 101 kPa {0 to - 76 cmHg}	PE-20	R ¹ / ₄ male thread and M5 female thread	NPN open-collector transistor
		North American		0 to - 101 kPa {0 to - 14.6 psi}	PE-20N		
		European		0 to - 101 kPa {0 to - 1.01 bar}	PE-20E	G ¹ / ₈ male thread and M5 female thread	PNP open-collector transistor
Positive pressure	100 kPa type	Asian		0 to 100 kPa {0 to 1.02 kgf/cm ² }	PE-21	R ¹ / ₄ male thread and M5 female thread	NPN open-collector transistor
		North American		0 to 100 kPa {0 to 14.5 psi}	PE-21N		
		European		0 to 100 kPa {0 to 1 bar}	PE-21E	G ¹ / ₈ male thread and M5 female thread	PNP open-collector transistor
	1 MPa type	Asian		0 to 1 MPa {0 to 10.2 kgf/cm ² }	PE-22	R ¹ / ₄ male thread and M5 female thread	NPN open-collector transistor
		North American		0 to 1 MPa {0 to 145 psi}	PE-22N		
		European		0 to 1 MPa {0 to 10 bar}	PE-22E	G ¹ / ₈ male thread and M5 female thread	PNP open-collector transistor

OPTIONS

Designation	Model No.	Description
Sensor mounting bracket	MS-PE-1	L-shaped bracket [Two M3 (length 8 mm 0.315 in) screws with washers are attached.]
Panel mounting bracket	MS-PE-2	It can be used for mounting on a panel (1 to 3.2 mm 0.039 to 0.126 in thick). [Two M3 (length 8 mm 0.315 in) screws with washers are attached.]
Front protection cover	MS-PE-3	It protects the sensor's adjustment panel. (It can be fitted when the panel mounting bracket is used.)

Sensor mounting bracket
• MS-PE-1

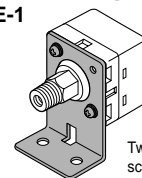

Two M3 (length 8 mm 0.315 in) screws with washers are attached.

Panel mounting bracket,
Front protection cover

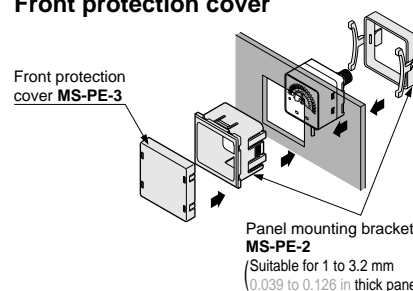

Panel mounting bracket
MS-PE-2
(Suitable for 1 to 3.2 mm
0.039 to 0.126 in thick panel)

SPECIFICATIONS

Item	Model No.	Vacuum pressure			Positive pressure					
		- 101 kPa type			100 kPa type			1 MPa type		
		Asian	North American	European	Asian	North American	European	Asian	North American	European
Type of pressure		Gauge pressure								
Rated pressure range		0 to - 101 kPa {0 to - 76 cmHg}	0 to - 101 kPa {0 to - 14. 6psi}	0 to - 101 kPa {0 to - 1.01 bar}	0 to 100 kPa {0 to 1.02 kgf/cm ² }	0 to 100 kPa {0 to 14.5 psi}	0 to 100 kPa {0 to 1 bar}	0 to 1 MPa {0 to 10.2 kgf/cm ² }	0 to 1 MPa {0 to 145 psi}	0 to 1 MPa {0 to 10 bar}
Set pressure range		- 10 to - 90 kPa {- 8 to - 68 cmHg}	- 10 to - 90 kPa {- 1.45 to - 13.1 psi}	- 10 to - 90 kPa {- 0.1 to - 0.9 bar}	10 to 90 kPa {0.1 to 0.92 kgf/cm ² }	10 to 90 kPa {1.45 to 13.1 psi}	10 to 90 kPa {0.1 to 0.9 bar}	0.1 to 0.9 MPa {1.0 to 9.2 kgf/cm ² }	0.1 to 0.9 MPa {14.5 to 131 psi}	0.1 to 0.9 MPa {1 to 9 bar}
Pressure withstandability		490 kPa						1.47 MPa		
Applicable fluid		Non-corrosive gas								
Hysteresis		5 % F.S. approx.								
Repeatability		Within ± 1 % F.S.								
Supply voltage		12 to 24 V DC ± 10 % Ripple P-P 10 % or less								
Current consumption		40 mA or less								
Output		<Asian, North American> NPN open-collector transistor • Maximum sink current: 100 mA • Applied voltage: 30 V DC or less (between output and 0 V) • Residual voltage: 1 V or less (at 100 mA sink current) 0.4 V or less (at 16 mA sink current)			<European> PNP open-collector transistor • Maximum source current: 100 mA • Applied voltage: 30 V DC or less (between output and + V) • Residual voltage: 2 V or less (at 100 mA source current)					
	Utilization category	DC-12 or DC-13								
	Output operation	ON above set pressure level or OFF above set pressure level, selectable with control input								
	Short-circuit protection	Incorporated								
Response time		10 ms or less								
Pressure display		Indication with red LED bar plus 1/2 step indicator (Green LED)								
	Display resolution	2.5 % F.S. or less								
Operation indicator		Red LED (lights up when the output is ON)								
Power indicator		Red LED (lights up when the power is ON)								
Environmental resistance	Pollution degree	3 (Industrial environment)								
	Protection	IP40 (IEC)								
	Ambient temperature	0 to + 50 °C + 32 to + 122 °F (No dew condensation), Storage: - 10 to + 60 °C + 14 to + 140 °F								
	Ambient humidity	35 to 85 % RH, Storage: 35 to 85 % RH								
	EMC	EN 50081-2, EN 50082-2, EN 61000-6-2								
	Voltage withstandability	1,000 V AC for one min. between all supply terminals connected together and enclosure								
	Insulation resistance	20 M Ω , or more, with 500 V DC megger between all supply terminals connected together and enclosure								
	Vibration resistance	10 to 150 Hz frequency, 0.75 mm 0.030 in amplitude in X, Y and Z directions for two hours each								
Shock resistance	100 m/s ² acceleration (10 G approx.) in X, Y and Z directions for three times each									
Temperature characteristics		Over ambient temperature range 0 to + 50 °C + 32 to + 122 °F: within ± 5 % F.S. of detected pressure at + 25 °C + 77 °F								
Pressure port		Asian: R ¹ / ₄ male thread and M5 female thread North American: NPT ¹ / ₄ male thread and 10-32UNF female thread European: G ¹ / ₈ male thread and M5 female thread								
Material		Front case: PBT, Rear case: PBT, Front panel: Polycarbonate, Pressure port: Brass (Nickel plated)								
Cable		0.18 mm ² 4-core cabtyre cable, 0.5 m 1.640 ft long								
Cable extension		Extension up to total 100 m 328.084 ft (less than 10 m 32.808 ft when conforming to CE marking) is possible with 0.18 mm ² , or more, cable.								
Weight		85 g approx.								

I/O CIRCUIT AND WIRING DIAGRAMS

NPN output type

I/O circuit diagram

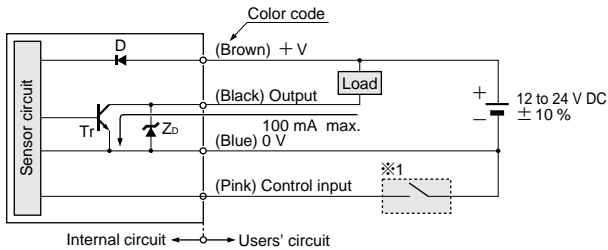

Symbols ... D : Reverse supply polarity protection diode
Zd: Surge absorption zener diode
Tr: NPN output transistor

※1: Output operation selection by control input

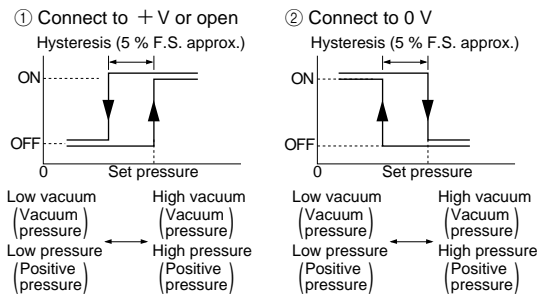

Wiring diagram

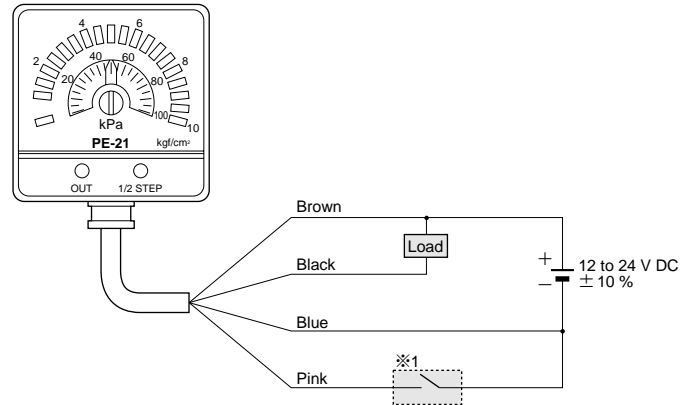

PNP output type

I/O circuit diagram

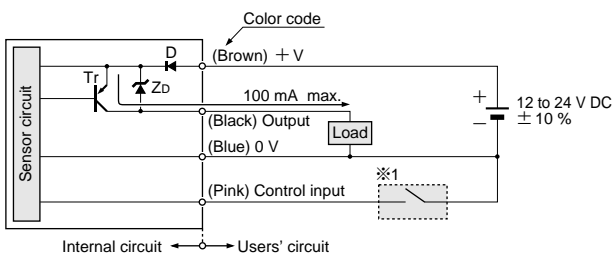

Symbols ... D : Reverse supply polarity protection diode
Zd: Surge absorption zener diode
Tr: PNP output transistor

※1: Output operation selection by control input

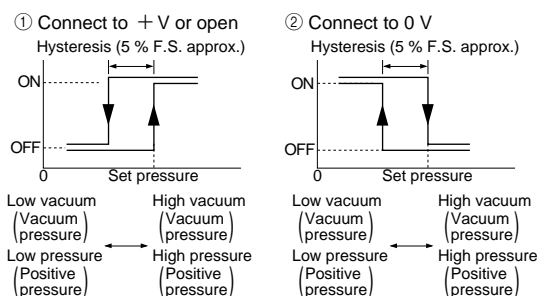

Wiring diagram

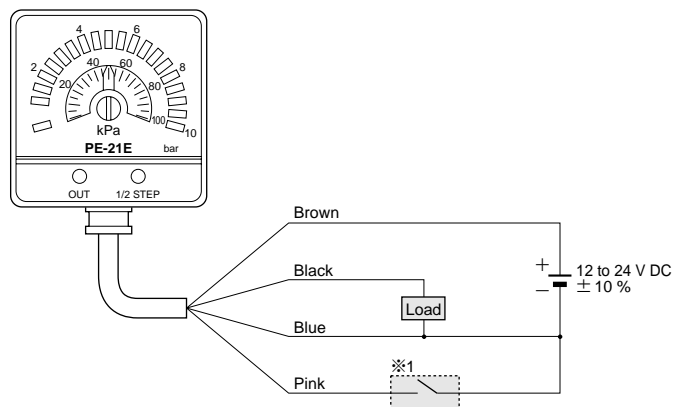

Head-separated

DP5/DPH

DP4

Digital Display

DP2

DP3

DP-M

LED Bar Display

PE

PRECAUTIONS FOR PROPER USE



- This product is not a safety sensor. Its use is not intended or designed to protect life and prevent body injury or property damage from dangerous parts of machinery. It is a normal pressure detection sensor.
- The PE series is designed for use with non-corrosive gas. It cannot be used with liquid or corrosive gas.

Piping

- When connecting a coupling to the pressure port, hold the hexagonal part of the pressure port with a 14 mm 0.551 in spanner and make sure that the tightening torque is under the value shown below.

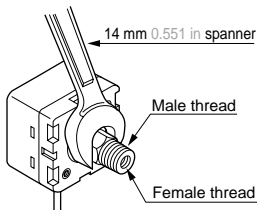

(Do not apply a spanner on) the enclosure.

The tightening torque should be 20 N·m or less with the male thread (R¹/₄, NPT¹/₄) and 2 N·m or less with the female thread (M5, 10-32UNF). Also, in order to prevent any leakage, wind a sealing tape on the male thread when connecting.

- For G¹/₈ thread of PE-□E, connect by using a commercial gasket (for G¹/₈).

Mounting

- If the sensor is mounted on the optional sensor mounting bracket, make sure that the tightening torque is 0.5 N·m or less.

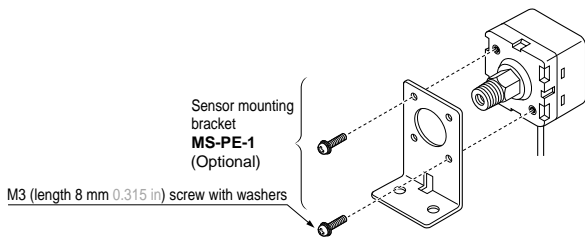

Error indication

- If the display is as shown in the right figure, excess current is flowing due to a load short-circuit. In this case, switch off the power supply and check the load and output.



Note: The right figure shows the vacuum pressure type sensor. In case of the positive pressure type sensor, the position of the indicators (red) is symmetrically opposite.

Wiring

- Make sure that the power supply is off while wiring.
- Verify that the supply voltage variation is within the rating.
- If power is supplied from a commercial switching regulator, ensure that the frame ground (F.G.) terminal of the power supply is connected to an actual ground.
- In case noise generating equipment (switching regulator, inverter motor, etc.) is used in the vicinity of this sensor, connect the frame ground (F.G.) terminal of the equipment to an actual ground.
- Do not run the wires together with high-voltage lines or power lines or put them in the same raceway. This can cause malfunction due to induction.

Functional description

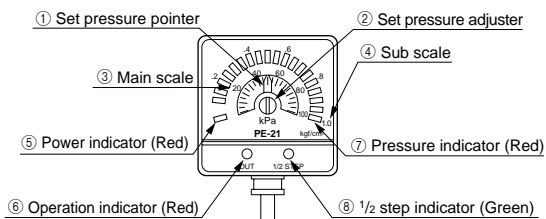

Note: In case of the vacuum pressure type, the position of the indicators (red) is symmetrically opposite.

Description	Function
① Set pressure pointer	Rotating the set pressure adjuster turns the pointer simultaneously. The value indicated by the pointer represents the set pressure level.
② Set pressure adjuster	Sets the threshold level. Vacuum pressure type • Rotating it counterclockwise, sets a higher vacuum level. Positive pressure type • Rotating it clockwise, sets a higher positive pressure level.
③ Main scale	“Pa” unit scale. It completely coincides with the LED bar display. PE-20□, PE-21□: kPa PE-22□: MPa
④ Sub scale	It is an additional scale. It does not completely coincide with the LED bar display. Use it as a reference. Pressure unit is, PE-20: cmHg PE-□N: psi PE-21, PE-22: kgf/cm ² PE-□E: bar
⑤ Power indicator (Red)	Lights up when the power is ON.
⑥ Operation indicator (Red)	Lights up when the output is ON.
⑦ Pressure indicator (Red)	Shows the measured pressure level.
⑧ 1/2 step indicator (Green)	By using the 1/2 step indicator in combination with the pressure indicator, the resolution can be increased to twice than that in case of using the pressure indicator only. (e.g.) = 80 kPa = 82.5 kPa Lights off Lights up

Note: It is possible that the position of the set pressure pointer and the position of the pressure indicator lighting up may not match. Use the set pressure pointer as a reference.

Others

- Use within the rated pressure range.
- Do not apply pressure exceeding the pressure with-standability value. The diaphragm will get damaged and correct operation shall not be maintained.
- Do not use during the initial transient time (50 ms) after the power supply is switched on.
- Avoid dust, dirt, and steam.
- Take care that the sensor does not come in direct contact with water, oil, grease, or organic solvents, such as, thinner, etc.
- Do not insert wires, etc., into the pressure port. The diaphragm will get damaged and correct operation shall not be maintained.

DIMENSIONS (Unit: mm in) The CAD data in the dimensions can be downloaded from the SUNX website: <http://www.sunx.co.jp/>

PE-□ Sensor

Asian (PE-□)

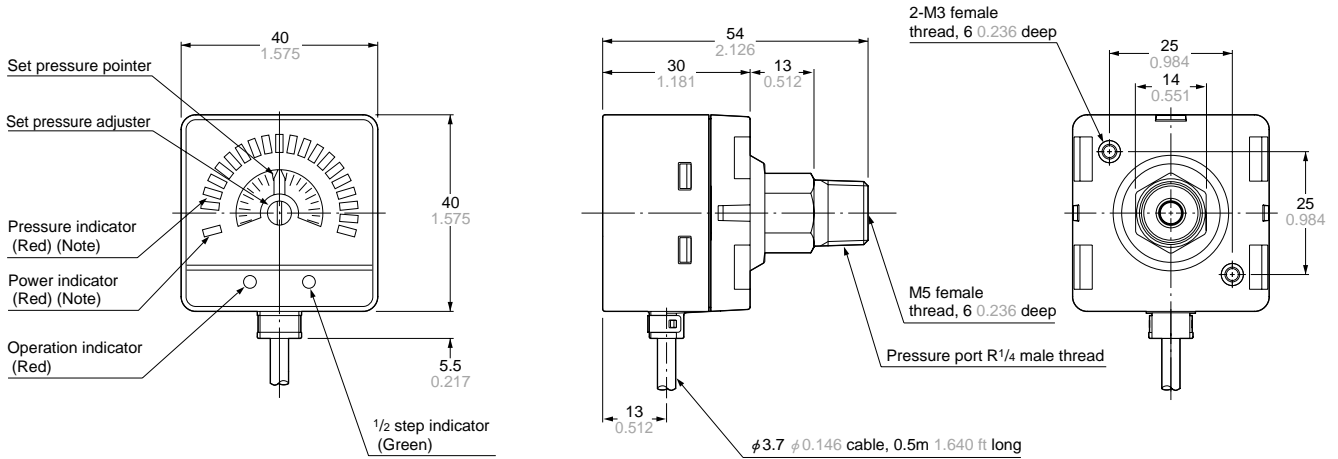

Note: The figure illustrates the indicator position for PE-21□ (positive pressure). For the vacuum pressure type, the indicator position is symmetrically opposite.

North American (PE-□N)

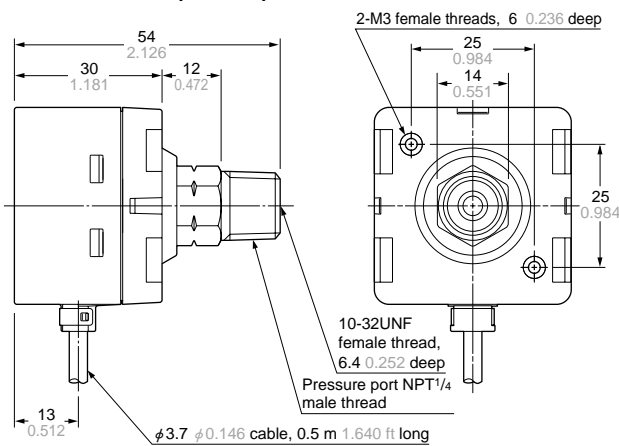

Note: The front view is the same as that for the Asian type.

European (PE-□E)

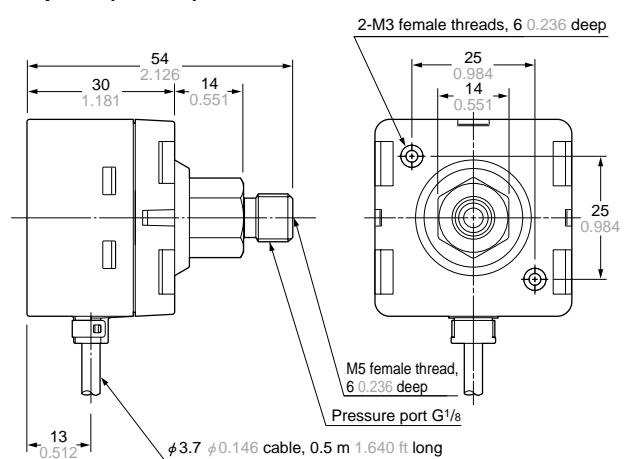

Note: The front view is the same as that for the Asian type.

MS-PE-1 Sensor mounting bracket (Optional)

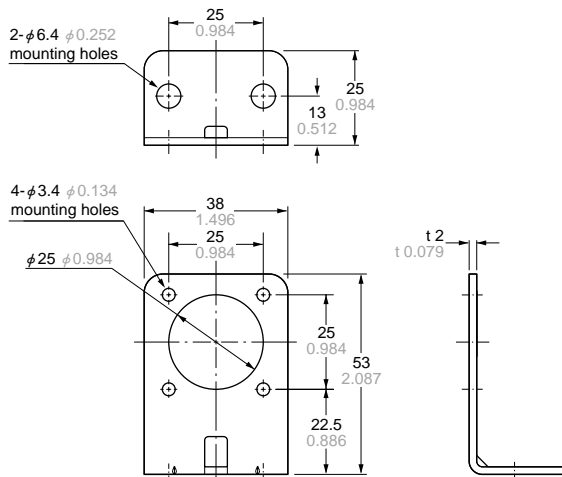

Material: Cold rolled carbon steel (SPCC)
Two M3 (length 8 mm 0.315 in) screws with washers are attached.

Assembly dimensions

Mounting drawing with PE-2□

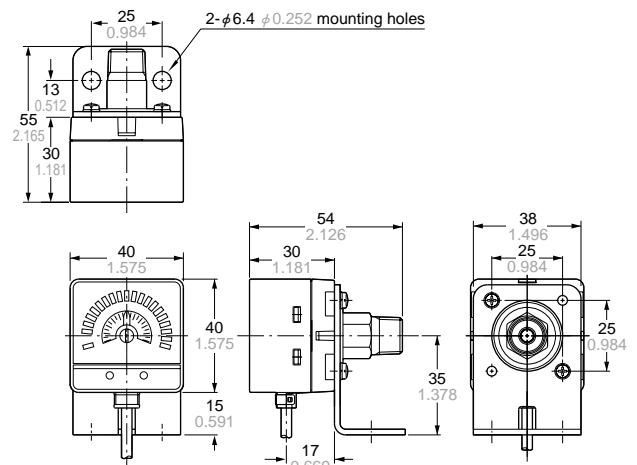

DIMENSIONS (Unit: mm in) The CAD data in the dimensions can be downloaded from the SUNX website: <http://www.sunx.co.jp/>

MS-PE-2
MS-PE-3 Panel mounting bracket, front protection cover (Optional)

Assembly dimensions

Mounting drawing with PE-2 □

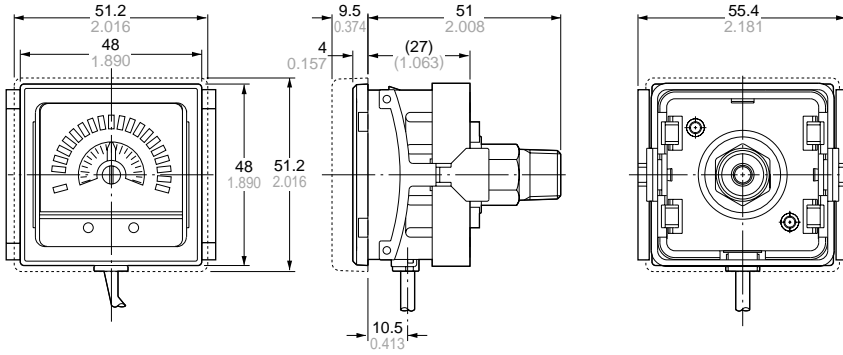

□ portion shows the front protection cover.
 Material: Polycarbonate (Front protection cover)
 Nylon 6, Polyacetal (Panel mounting bracket)

Panel cut-out dimensions

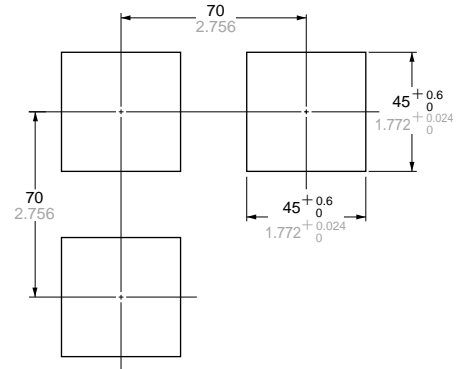

Note: The panel thickness should be 1 to 3.2 mm
 0.039 to 0.126 in.

DP5/DPH
Head-separated

DP4

DP2
Digital Display

DP3
Digital Display

DP-M

PE
LED Bar Display