

PM SERIES

U-shaped Micro Photoelectric Sensor

AUDIN

Composants & systèmes d'automatisme
7 bis rue de Tinquex - 51100 Reims - France
Tel. +33(0)326042021 • Fax +33(0)326042820
http://www.audin.fr • e-mail info@audin.fr

MS-AJ

Sensor Mounting Stand

PM

Micro

PM2

NX5

Multi-voltage Type

VF

Multi-voltage Type

SU-7/SH

Amplifier-separated Type

SS-A5

Amplifier-separated Type

CHX-SC2

Sensor Checker

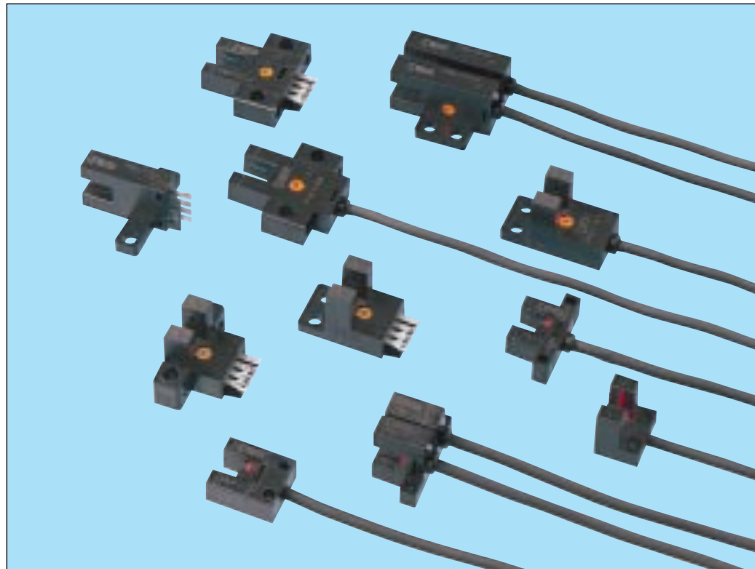

Extremely Small Size
Enables Space Saving
and Quick Installation!

CE Marked

Conforming to EMC Directive

Extremely Small

Ultra-small type **PM-□24(-R)** contributes to the miniaturization of your equipment. Even the small cable type has become very compact.

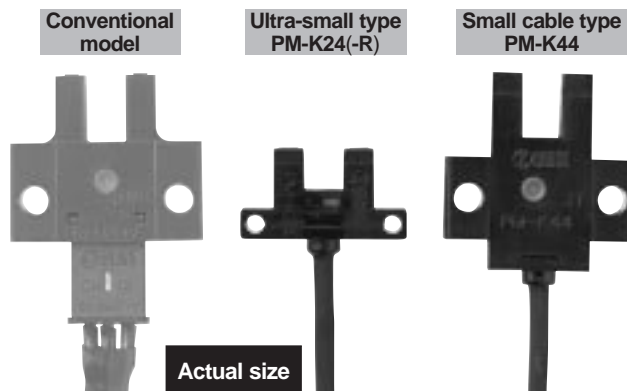

Equipped with Two Independent Outputs

All models are equipped with two independent outputs – Light-ON and Dark-ON. Hence, one model suffices even if the output is to be used differently, depending upon the location of use.

Also, since two independent outputs have been provided, cumbersome handling of the output conversion control input, or fear of logic inversion due to a cable break, is eliminated. The sensor can be connected to the existing wiring as it is.

Example of connection with a commercial intermediate connector

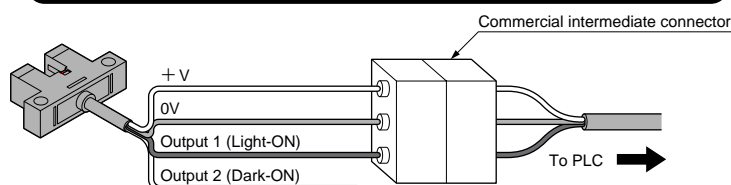

Just connect the cable of the used output (either Light-ON or Dark-ON).

Connected device side can be left as it is.

Note: Ensure to insulate the unused output wire.

Quick Fitting Hook-up Connector

Easy to maintain connector type models are available. Its exclusive connector is the industry's first hook-up connector. Since only crimping with exclusive pliers is to be done, cumbersome soldering or insulation is absolutely not required. Further, connector attached cable is also available.

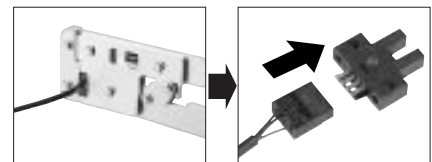

Crimp the connector on the cable.

Quick connection to the sensor.

Wide Model Variety

A wide variety of 17 shapes and 29 models is available. You may select from this wide range to suit the mounting conditions.

Meets Global Requirements

Conforms to Europe's EMC Directive. Both, NPN and PNP output models are available.

APPLICATIONS

Sensing the starting point on a rotating body

The starting point can be sensed by making a slit in the rotating body.

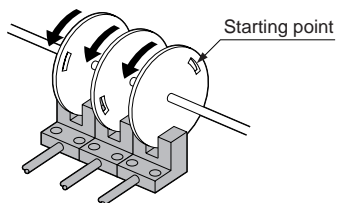

Determining the pallet position

Pallet is stopped by sensing the dog.

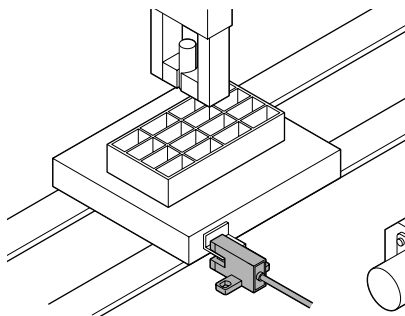

Sensing the starting point and overrun of a moving body

Starting point and overrun is sensed using the dog on the base.

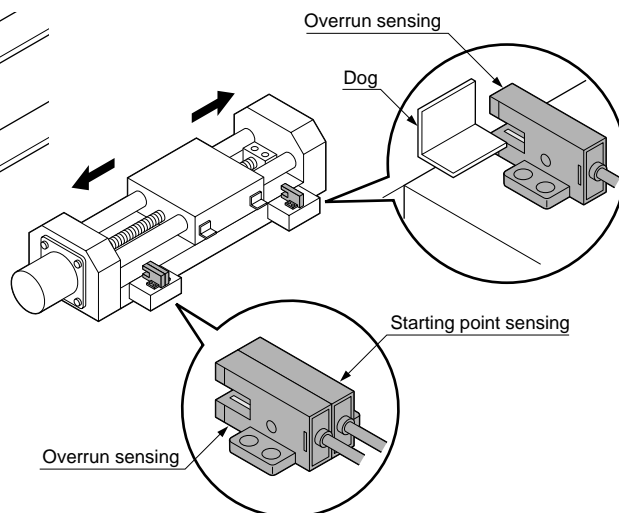

ORDER GUIDE

Type	Appearance (mm)	Sensing range	Model No. (Note)	Output	Output operation
Ultra-small		5mm (fixed)	PM-K24	NPN open-collector transistor	Incorporated with 2 outputs: Light-ON/Dark-ON
			PM-K24-R		
			PM-L24		
			PM-L24-R		
			PM-F24		
			PM-F24-R		
			PM-R24		
			PM-R24-R		
			PM-U24		
			PM-U24-R		

Note: The suffix '-R' indicates a inflection resistant cable type.

Sensor Mounting Stand
MS-AJ

PM

Micro
PM2

Multi-voltage Type
NX5

VF

Amplifier-separated Type
SU-7/SH

SS-A5

Sensor Checker
CHX-SC2

ORDER GUIDE

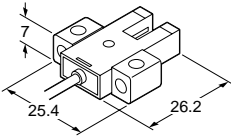
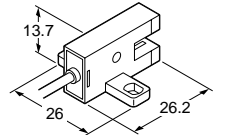
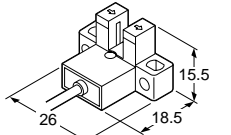
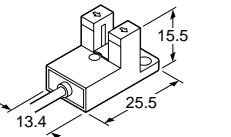
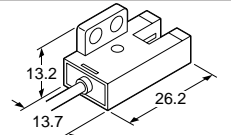
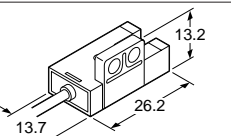
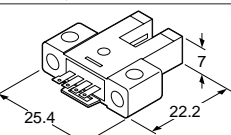
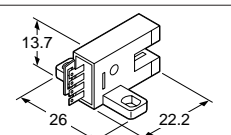
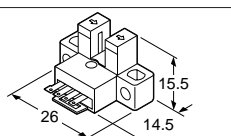
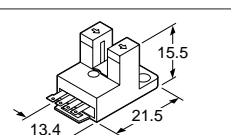
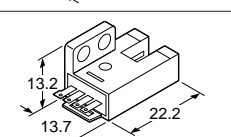
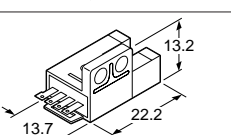
Type	Appearance (mm)	Sensing range	Model No.	Output	Output operation				
Small	With cable	5mm (fixed)	K type		PM-K44	NPN open-collector transistor			
					PM-K44P	PNP open-collector transistor			
			T type		PM-T44	NPN open-collector transistor			
					PM-T44P	PNP open-collector transistor			
			L type		PM-L44	NPN open-collector transistor			
					PM-L44P	PNP open-collector transistor			
			Y type		PM-Y44	NPN open-collector transistor			
					PM-Y44P	PNP open-collector transistor			
			F type		PM-F44	NPN open-collector transistor			
					PM-F44P	PNP open-collector transistor			
			R type		PM-R44	NPN open-collector transistor			
					PM-R44P	PNP open-collector transistor			
			Small	With connector	5mm (fixed)	K type		PM-K54	NPN open-collector transistor
								PM-K54P	PNP open-collector transistor
T type		PM-T54				NPN open-collector transistor			
		PM-T54P				PNP open-collector transistor			
L type		PM-L54				NPN open-collector transistor			
		PM-L54P				PNP open-collector transistor			
Y type		PM-Y54				NPN open-collector transistor			
		PM-Y54P				PNP open-collector transistor			
F type		PM-F54				NPN open-collector transistor			
		PM-F54P				PNP open-collector transistor			
R type		PM-R54				NPN open-collector transistor			
		PM-R54P				PNP open-collector transistor			

Incorporated with 2 outputs: Light-ON/Dark-ON

OPTIONS

Designation	Model No.	Description	
Connector	CN-14	Connector for soldering	
Hook-up connector	CN-14H	This connector can be hooked-up on 0.08 to 0.2mm ² cable simply in one grip. Wire diameter: ϕ 0.7 to ϕ 1.2mm	
	CN-14H-2	Suitable for UL standard cable. This connector can be hooked-up on 0.18 to 0.22mm ² cable simply in one grip. Wire diameter: ϕ 1.2 to ϕ 1.52mm	
Connector attached cable	CN-14H-C1	Length: 1m	For the connector type, with 0.18mm ² 4-core cabtyre cable Cable diameter: ϕ 3.8mm
	CN-14H-C3	Length: 3m	
Hook-up pliers	CN-HP	These are exclusive pliers for hook-up connectors CN-14H and CN-14H-2 .	
Mounting screw	MS-M2	Mounting screw with washers for the ultra-small type sensor (50 Nos. lot). It can mount securely as it is spring washer attached.	

Connector

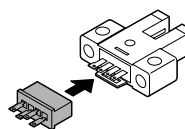

Hook-up connector

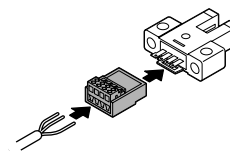

Connector attached cable

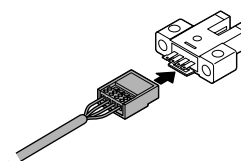

Hook-up pliers

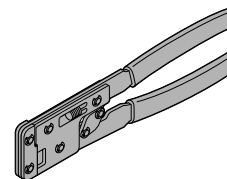

Mounting screw



Sensor Mounting Stand
MS-AJ

Micro PM

PM2

Multi-voltage Type
VF NX5

Amplifier-separated Type
SU-7/SH

SS-A5

Sensor Checker
CHX-SC2

SPECIFICATIONS

Item	Model No.	Type	Ultra-small		Small	
			NPN output type	With inflection resistant cable	With cable	With connector
PNP output type				PM-□44P	PM-□54P	
Sensing range		5mm (fixed)				
Minimum sensing object		0.8 × 1.8mm opaque object				
Hysteresis		0.05mm or less				
Repeatability		0.03mm or less				
Supply voltage		5 to 24V DC ± 10% Ripple P-P 10% or less				
Current consumption		15mA or less				
Output		<NPN output type> NPN open-collector transistor • Maximum sink current: 50mA • Applied voltage: 30V DC or less (between output and 0V) • Residual voltage: 0.7V or less (at 50mA sink current) 0.4V or less (at 16mA sink current)		<PNP output type> PNP open-collector transistor • Maximum source current: 50mA • Applied voltage: 30V DC or less (between output and +V) • Residual voltage: 0.7V or less (at 50mA source current) 0.4V or less (at 16mA source current)		
Utilization category		DC-12 or DC-13				
Output operation		Incorporated with 2 outputs: Light-ON/Dark-ON				
Response time		Under light received condition: 20 μs or less Under light interrupted condition: 100 μs or less (Response frequency: 1kHz or more)(Note 1)				
Operation indicator		Vermilion LED (lights up under light received condition)				
Pollution degree		3 (Industrial environment)				
Ambient temperature (Note 2, 3)		- 25 to + 55°C (No dew condensation or icing allowed), Storage: - 30 to + 80°C				
Ambient humidity		35 to 85% RH, Storage: 35 to 85% RH				
Ambient illuminance		Fluorescent light: 1,000 lx at the light-receiving face				
EMC		Emission: EN50081-2, Immunity: EN50082-2				
Voltage withstandability		1,000V AC for one min. between all supply terminals connected together and enclosure				
Insulation resistance		50MΩ, or more, with 250V DC megger between all supply terminals connected together and enclosure				
Vibration resistance		10 to 2,000Hz frequency, 1.5mm amplitude in X, Y and Z directions for two hours each				
Shock resistance		15,000m/s ² acceleration (1,500G approx.) in X, Y and Z directions for three times each				
Emitting element		Infrared LED (non-modulated)				
Material		Enclosure: PBT, Slit cover: Polycarbonate, Terminal part [PM-□54(P) only]: Solder plated				
Cable		0.09mm ² 4-core cabtyre cable (PM-□24-R: 0.1mm ² inflection, oil and heat resistant cabtyre cable), 1m long				
Cable extension		Extension up to total 100m is possible with 0.3mm ² , or more, cable.				
Weight		10g approx.		15g approx.		3g approx.

Notes: 1) The response frequency is the value when the disc, given in the figure below, is rotated.

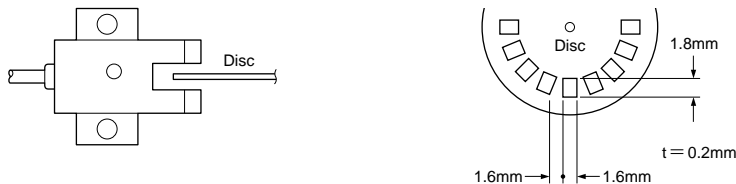

- 2) In case the ultra-small type PM-□24(-R) is used at an ambient temperature of + 50°C, or more, make sure to mount it on a metal body.
- 3) Take care that the flexibility of the PM-□24-R cable is lost if the ambient temperature is near - 10°C.

I/O CIRCUIT AND WIRING DIAGRAMS

PM-□24 PM-□24-R
PM-□44 PM-□54

NPN output type

I/O circuit diagram

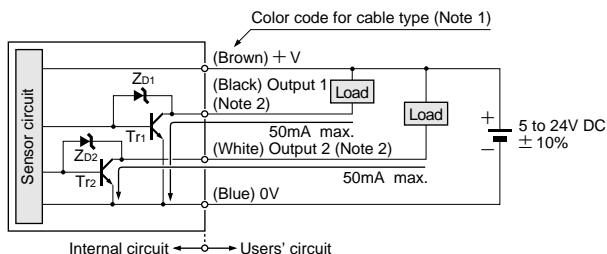

Notes: 1) The color code of the connector attached cable is also the same.
2) Ensure to insulate the unused output wire.

Symbols ... ZD1, ZD2: Surge absorption zener diode
Tr1, Tr2 : NPN output transistor

Wiring diagram

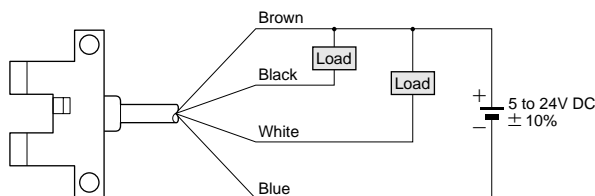

Output operation

	Color code	Output operation
Output 1	Black	Light-ON
Output 2	White	Dark-ON

PM-□44P
PM-□54P

PNP output type

I/O circuit diagram

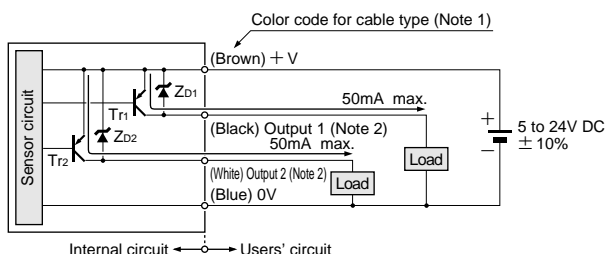

Notes: 1) The color code of the connector attached cable is also the same.
2) Ensure to insulate the unused output wire.

Symbols ... ZD1, ZD2: Surge absorption zener diode
Tr1, Tr2 : PNP output transistor

Wiring diagram

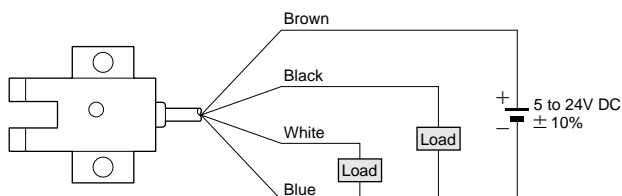

Output operation

	Color code	Output operation
Output 1	Black	Light-ON
Output 2	White	Dark-ON

PRECAUTIONS FOR PROPER USE

Refer to P.820~ for general precautions.

All models



This product is not a safety sensor. Its use is not intended or designed to protect life and prevent body injury or property damage from dangerous parts of machinery. It is a normal object detection sensor.

Wiring

- Please carry out the wiring carefully since protection circuits against reverse power supply connection and output short-circuit are not incorporated.

Others

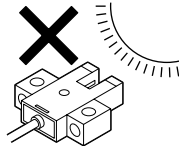
- Since the sensor is intended for use inside machines, no special countermeasures have been taken against extraneous light. Take care that extraneous light is not directly incident on the beam receiving section. 
- Do not use during the initial transient time (50ms) after the power supply is switched on.
- The cable of **PM-□24-R** is a flexible cable usable on a moving base. When the sensor is mounted on a moving base, fix the sensor cable joint so that stress is not applied to it.
- Take care that the flexibility of the **PM-□24-R** cable is lost if the ambient temperature is near -10°C .

Sensor Mounting Stand
MS-AJ

PM

Micro

PM2

Multi-voltage Type

NX5

VF

Amplifier-separated Type

SU-7/SH

Amplifier-separated Type

SS-A5

Sensor Checker

CHX-SC2

PRECAUTIONS FOR PROPER USE

Refer to P.820~ for general precautions.

All models

Mounting

- When fixing the sensor with screws, use M3 screws [M2 screws in case of **PM-□24(-R)**] and the tightening torque should not exceed the values given below. Further, use small, round type plain washers. (M3: ϕ 6mm, M2: ϕ 4.3mm)

Model No.	Tightening torque
PM-□24(-R)	0.15N·m
PM-□44(P)	0.5N·m
PM-□54(P)	

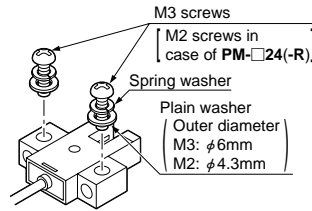

Note: In case the ultra-small type **PM-□24(-R)** is used at an ambient temperature of +50°C, or more, make sure to mount it on a metal body.

Cable extension

- Cable extension is possible up to an overall length of 100m with a 0.3mm², or more, cable. However, since a voltage drop shall occur due to the cable extension, ensure that the power supply voltage at the end of the cable attached to the sensor or at the sensor terminals is within the rating.

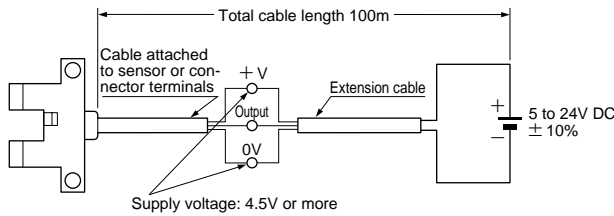

But, when the overall cable length, including the cable attached to the sensor, is as given below, there is no need to confirm the voltage.

Conductor cross-section area	Total cable length
0.08 to 0.1mm ²	Up to 5m
0.2mm ²	Up to 10m
0.3mm ²	Up to 20m

DIMENSIONS (Unit: mm)

PM-K24 PM-K24-R Sensor

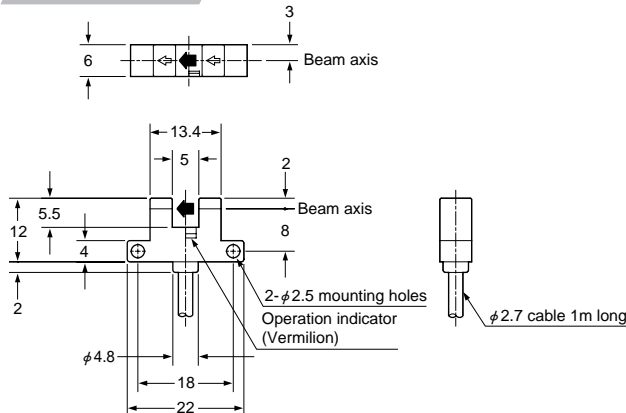

PM-L24 PM-L24-R Sensor

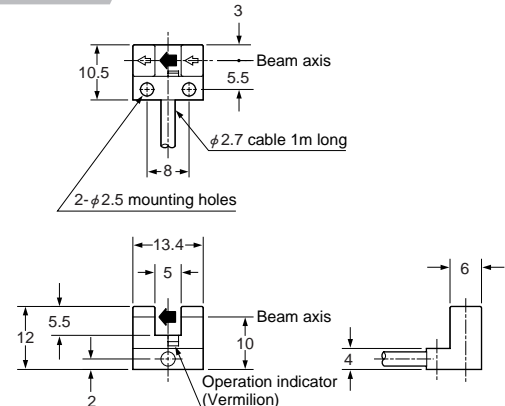

PM-□54 PM-□54P

Crimping of hook-up connectors CN-14H and CN-14H-2

Item	Model No.	CN-14H	CN-14H-2
Conductor cross-section area		0.08 to 0.2mm ² (AWG28 to AWG24)	0.18 to 0.22mm ² (AWG25 to AWG24)
Wire diameter		ϕ 0.7 to ϕ 1.2mm	ϕ 1.2 to ϕ 1.52mm
Wire insulation material		Vinyl chloride or soft polyethylene	

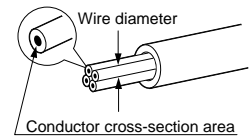

Crimping method

- Strip the cable sheath 15mm, or more, and insert the wires into the connector insertion holes till the wire tips reach the end.

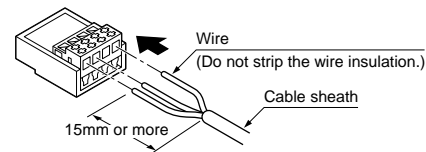

Arrangement of connector terminals

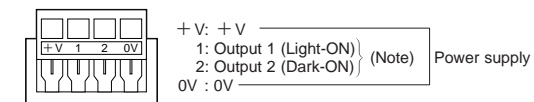

- Crimp with the exclusive hook-up pliers **CN-HP**.

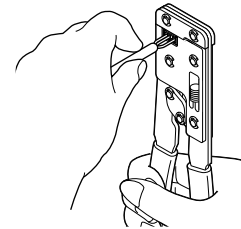

Caution: Make sure to use the exclusive hook-up pliers **CN-HP**. Commercially available pliers cannot be used.

Soldering

- If soldering is done directly on the terminals, strictly adhere to the conditions given below.

Item	Model No.	PM-□54(P)
Soldering temperature		260°C or less
Soldering time		3 sec. or less
Soldering position		Refer to the right figure

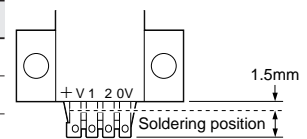

DIMENSIONS (Unit: mm)

**PM-F24
PM-F24-R** Sensor

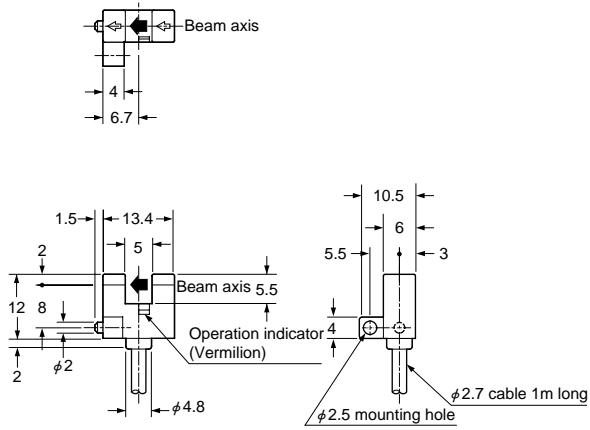

**PM-R24
PM-R24-R** Sensor

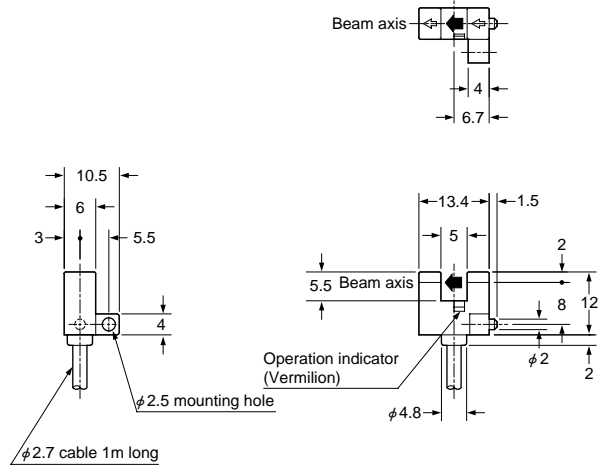

**PM-U24
PM-U24-R** Sensor

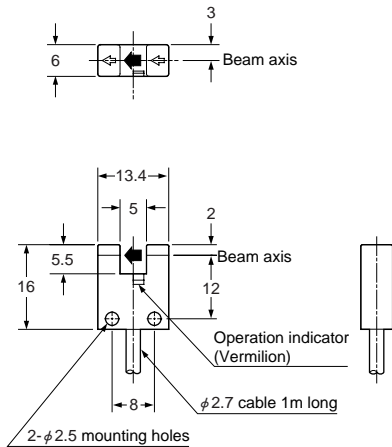

**PM-K44
PM-K44P** Sensor

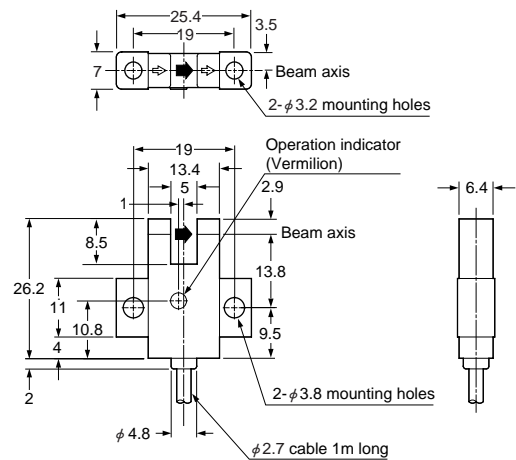

**PM-T44
PM-T44P** Sensor

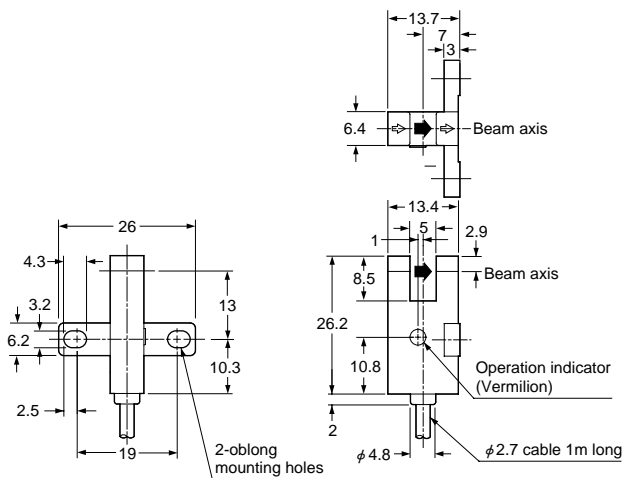

**PM-L44
PM-L44P** Sensor

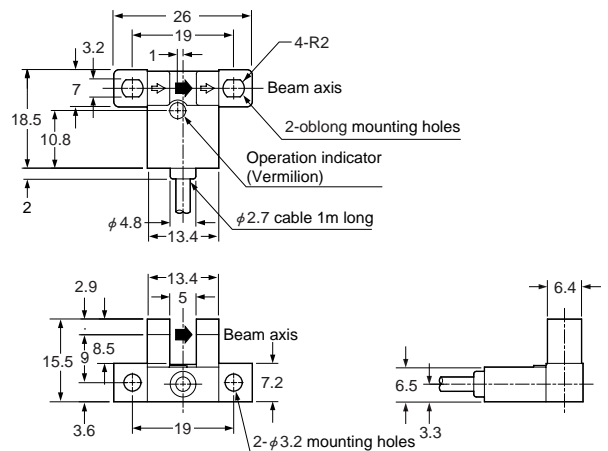

Sensor Mounting Stand
MS-AJ

Micro
PM
PM2

Multi-voltage Type
NX5
VF

Amplifier-separated Type
SU-7/SH

SS-A5

Sensor Checker
CHX-SC2

DIMENSIONS (Unit: mm)

**PM-Y44
PM-Y44P** Sensor

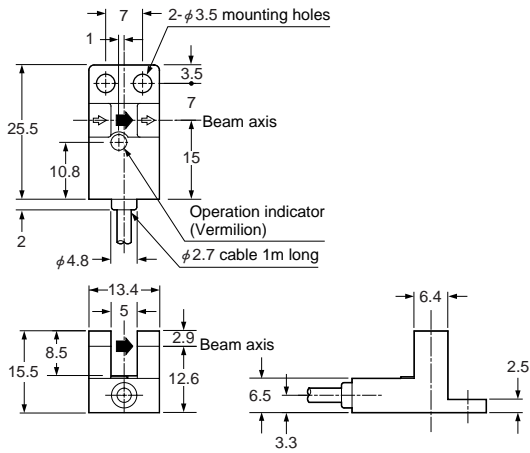

**PM-F44
PM-F44P** Sensor

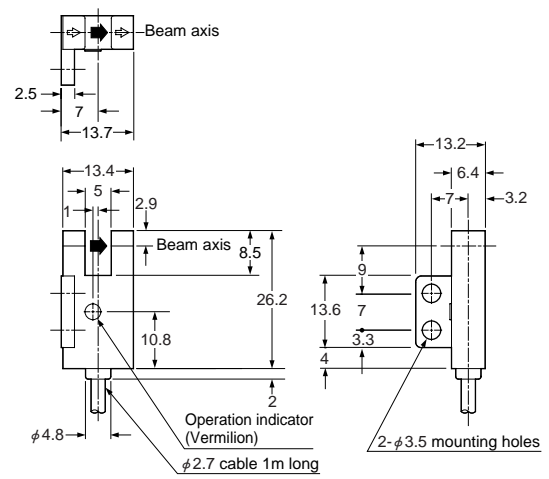

**PM-R44
PM-R44P** Sensor

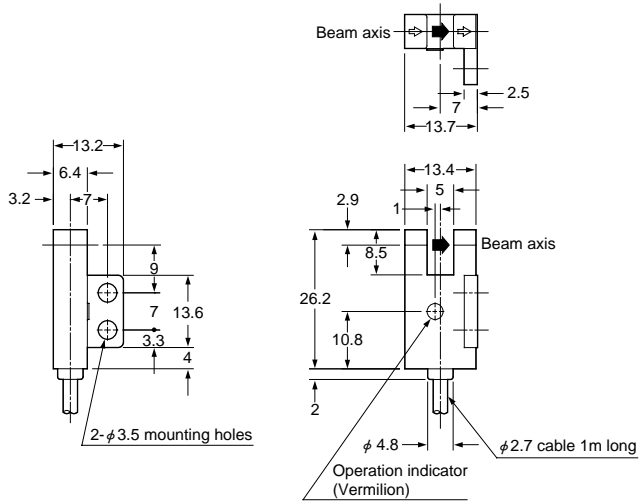

**PM-K54
PM-K54P** Sensor

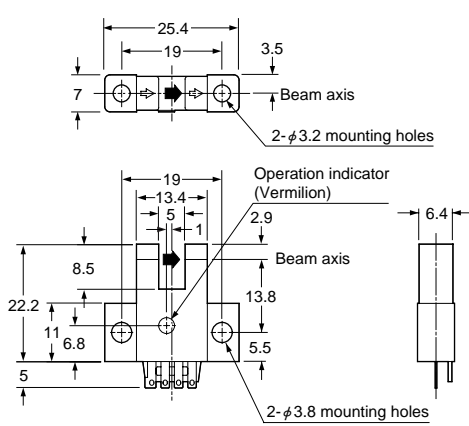

**PM-T54
PM-T54P** Sensor

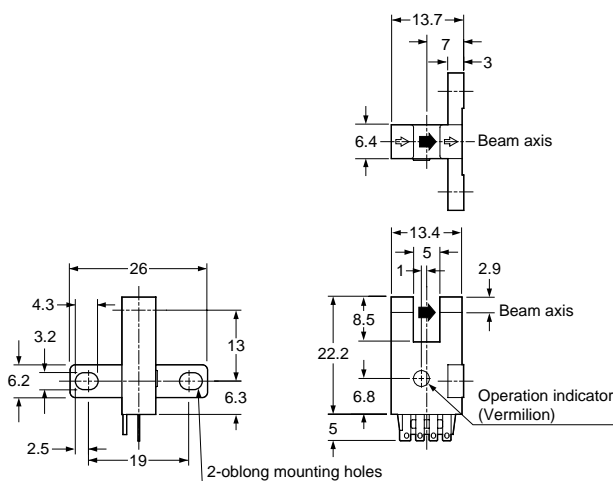

**PM-L54
PM-L54P** Sensor

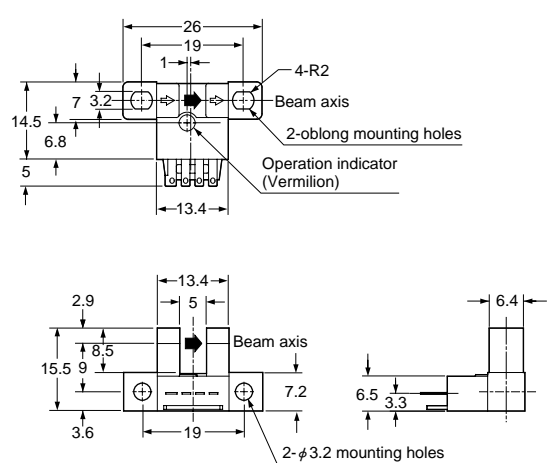

DIMENSIONS (Unit: mm)

PM-Y54
PM-Y54P Sensor

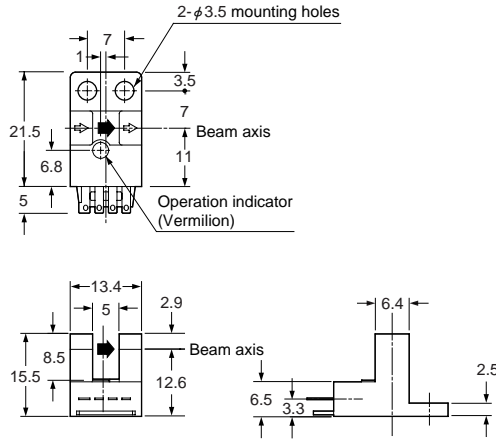

PM-F54
PM-F54P Sensor

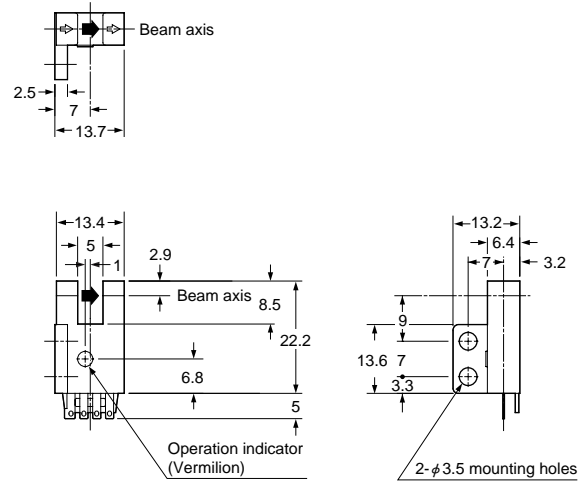

PM-R54
PM-R54P Sensor

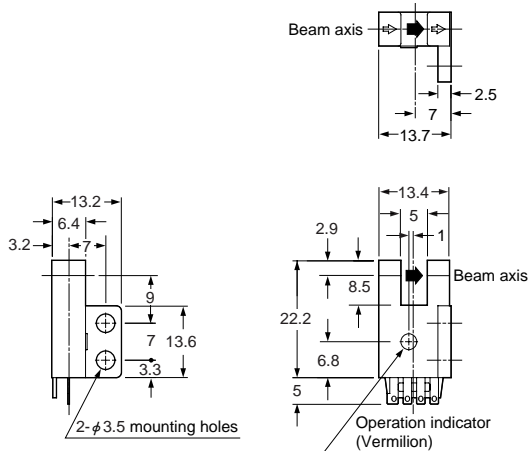

※Terminal part (**PM-□54**, **PM-□54P**)

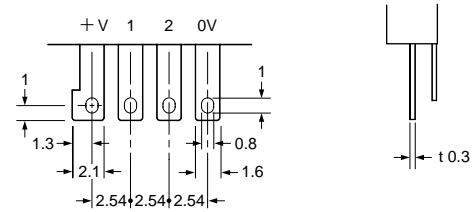

CN-14H
CN-14H-2 Hook-up connector (Optional)

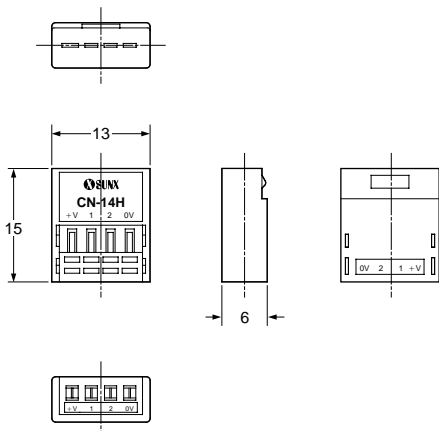

CN-14 Connector (Optional)

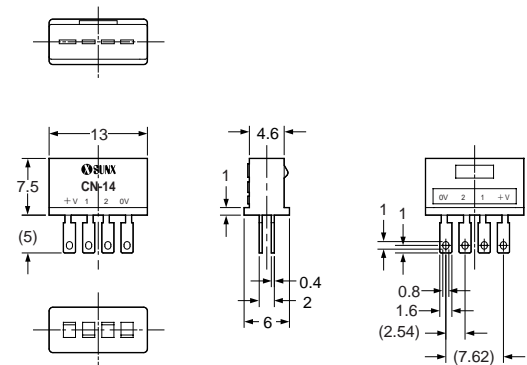

CN-14H-C1
CN-14H-C3 Connector attached cable (Optional)

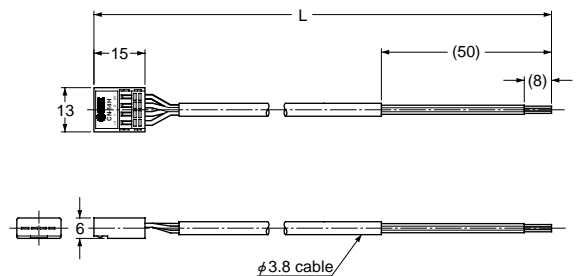

• Cable length L

Model No.	Cable length
CN-14H-C1	1m
CN-14H-C3	3m

Sensor Mounting Stand
MS-AJ

Micro
PM
PM2

Multi-voltage Type
NX5
VF

Amplifier-separated Type
SU-7/SH

SS-A5

Sensor Checker
CHX-SC2