

INSTRUCTION MANUAL

Small/Slim Object Detection Area Sensor NA1-11, NA1-11-PN



- **If this product is used as a sensing device for personnel protection, serious body injury or death could result.**
- Never use this product as a sensing device with any press machine, shearing machine, roll grinding machine, forming machine, vulcanizer, or robot etc. for protection of a hand or a part of the body.
- This product does not include a self-checking circuit for safety functions necessary to allow its use as a safety device. Thus, a system failure or malfunction can result in either an energized or a de-energized output condition.
- When this product is used as a sensing device in the following applications and if a problem relating to 'law' or 'product liability' occurs, SUNX shall not be liable for the failure and for the damage or less.
 - 1) Use of this product installed to a machinery or a device as a sensing device to detect a hand or a part of the operator's body entering a dangerous area and stop the machinery or the device.
 - 2) Installation of this product to a protection device for preventing to enter a dangerous area and use of this as a sensing device which detects a hand or a part of the operator's body and open/close the door or window.
 - 3) Use of this product as a sensing device for personnel protection (including interlock).
- For sensing devices to be used as safety devices for press machines or for personnel protection, use products which meet standards, such as OSHA, ANSI or IEC etc., for personnel protection applicable in each region or country.
- In case of using as a safety device for press machines, use a product approved by the Ministry of Labor in Japan.

1 SPECIFICATIONS

Type		NPN output	PNP output	
Item	Model No. (Note 1)	NA1-11	NA1-11-PN	
Sensing height		100mm		
Sensing range (Note 1)		0.17 to 1m		
Element pitch		10mm		
Number of emitting/receiving elements		11 Nos. each on the emitter and the receiver, respectively		
Sensing object		φ 13.5mm or more opaque object (Note 2)		
Supply voltage		12 to 24V DC ± 10% Ripple P-P 10% or less		
Current consumption		Emitter: 80mA or less, Receiver: 100mA or less		
Output		NPN open-collector transistor • Maximum sink current: 100mA • Applied voltage: 30V DC or less (between output and 0V) • Residual voltage: 1V or less (at 100mA sink current) 0.4V or less (at 16mA sink current)	PNP open-collector transistor • Maximum source current: 100mA • Applied voltage: 30V DC or less (between output and +V) • Residual voltage: 1V or less (at 100mA source current) 0.4V or less (at 16mA source current)	
	Output operation	ON or OFF when the beam channel is interrupted, selectable by operation mode switch		
	Short-circuit protection	Incorporated		
Response time		In Dark state: 5ms or less, In Light state: 10ms or less		
Indicators	Emitter	Power	Green LED (lights up when the power is ON)	
		Large	Orange LED lights up or blinks when the large indicator input is Low, lighting pattern is selected by operation mode switch	Orange LED lights up or blinks when the large indicator input is High, lighting pattern is selected by operation mode switch
			Operation	Orange LED (lights up when the output is ON)
	Receiver	Power	Green LED (lights up when the power is ON)	
		Large	Orange LED lights up or blinks when the large indicator input is Low, lighting pattern is selected by operation mode switch	Orange LED lights up or blinks when the large indicator input is High, lighting pattern is selected by operation mode switch
			Operation	Orange LED (lights up when the output is ON)
Ambient temperature		-10 to +55°C (No dew condensation or icing allowed) Storage: -20 to +70°C		
Ambient humidity		35 to 85% RH, Storage: 35 to 85% RH		
Emitting element		Infrared LED (Cross-beam scanning system)		
Material		Enclosure: Heat-resistant ABS, Lens: Acrylic Indicator cover: Acrylic		
Cable		0.3mm ² 4-core (emitter: 3-core) oil-resistant cabtyre cable, 2m long		
Weight		Emitter: 80g approx., Receiver: 85g approx.		

Notes: 1) The model No. with suffix '-C5' is 5m cable length type. (only NPN output type)
Model No.: **NA1-11-C5**

- 2) The sensing range gives the mounting distance between the emitter and the receiver. An object can be detected even if it is 0.17m, or less, away.
- 3) Although this product can detect slim objects by using the cross-beam scanning system, the size of the slim object which can be stably detected differs with the setting distance. When this sensor is used to detect slim objects, make sure to confirm stable detection using the actual objects.

2 CAUTIONS

- Make sure that the power supply is off while wiring or the operation of the operation mode switch.
- Take care that wrong wiring may damage the sensor.
- Verify that the supply voltage variation is within the rating.
- If power is supplied from a commercial switching regulator, ensure that the frame ground (F.G.) terminal of the power supply is connected to an actual ground.
- In case noise generating equipment (switching regulator, inverter motor, etc.) is used in the vicinity of this product, connect the frame ground (F.G.) terminal of the equipment to an actual ground.
- Do not run the wires together with high-voltage lines or power lines or put them in the same raceway. This can cause malfunction due to induction.
- Extension up to total 100m is possible, for both emitter and receiver, with 0.3mm², or more, cable. However, in order to reduce noise, make the wiring as short as possible.
- Do not use during the initial transient time (0.5 sec.) after the power supply is switched on.
- Avoid dust, dirt, and steam.
- Take care that the sensor does not come in direct contact with water, oil, grease, or organic solvents, such as, thinner, etc.
- Take care that the sensor is not directly exposed to fluorescent light from a rapid-starter lamp or a high frequency lighting device, as it may affect the sensing performance.
- The emitter and the receiver must face each other with their cable ends on the same side. If they are set upside down, the sensor will not work correctly.
- This sensor is suitable for indoor use only.
- Although this product can detect slim objects by using the cross-beam scanning system, the size of the slim object which can be stably detected differs with the setting distance. Hence, when the product is used to detect slim objects, make sure to confirm stable detection using the actual objects.
- In case of this sensor, light from the emitter spreads above and below the sensor. Hence, take care that if there is a reflective object above or below the product it will affect the sensing.

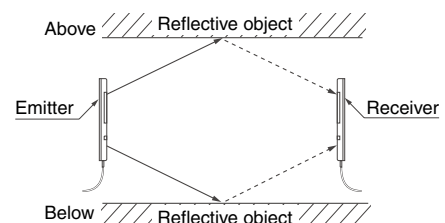

3 MOUNTING

- Use M4 screws with washers and M4 nuts. The tightening torque should be 0.5N·m or less. During mounting, do not apply any bending or twisting force to the sensor. (Please arrange the screws and nuts separately.)

- Sensor mounting brackets (MS-NA1-1, MS-NA2-1) are also available.

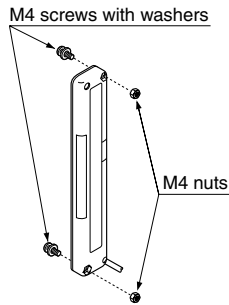

MS-NA1-1 assembly drawing

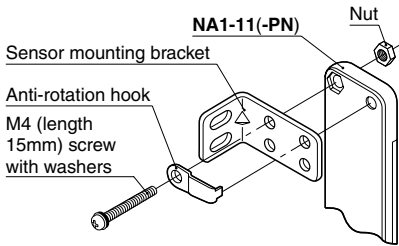

MS-NA2-1 assembly drawing

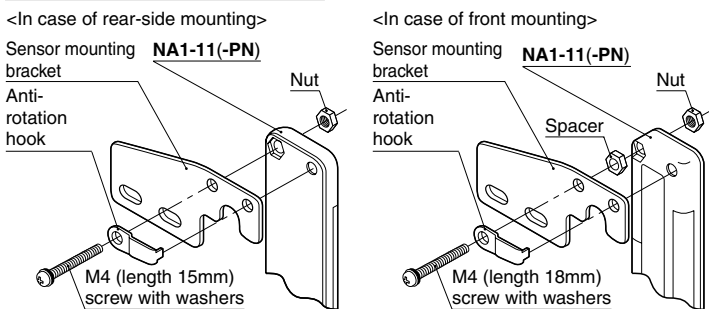

4 I/O CIRCUIT DIAGRAMS

- NA1-11 / NPN output type

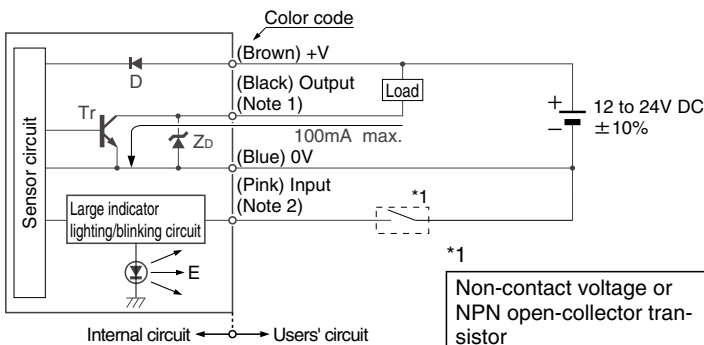

- Notes: 1) The emitter is not incorporated with the output (black).
 2) In order to use the large indicators as large size operation indicators connect input (pink) and output (black) wires together.
 3) Insulate all unused wires individually to avoid miscontact.

Symbols...D : Reverse supply polarity protection diode
 Zd : Surge absorption zener diode
 Tr : NPN output transistor
 E : Large indicator

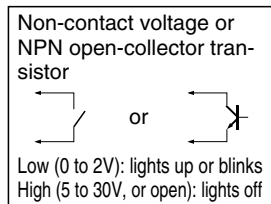

- NA1-11-PN / PNP output type

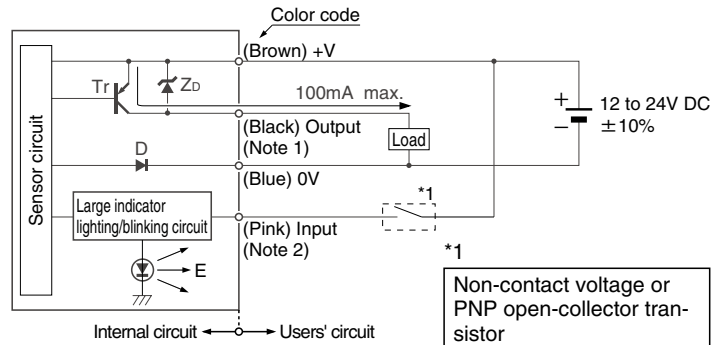

- Notes: 1) The emitter is not incorporated with the output (black).
 2) In order to use the large indicators as large size operation indicators connect input (pink) and output (black) wires together.
 3) Insulate all unused wires individually to avoid miscontact.

Symbols...D : Reverse supply polarity protection diode
 Zd : Surge absorption zener diode
 Tr : PNP output transistor
 E : Large indicator

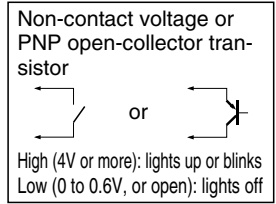

5 SELECTION OF LARGE INDICATOR OPERATION

- Lighting/blinking is selected by the operation mode switch on the emitter and the receiver.

Operation of large indicator	Operation mode switch	
	Emitter	Receiver
Lighting	LIGHT BLINK	LIGHT BLINK
Blinking	LIGHT BLINK	LIGHT BLINK

6 SELECTION OF OUTPUT OPERATION

- The output operation mode is selected by the operation mode switch on the receiver.
 (The switches must be set with the power supply off. The operation mode does not change if the switch setting is changed with the power supplied.)

Operation mode switch	Output operation	Operation indicator (Orange)	Receiver
D-ON	ON in Dark state	Lights up when the output is ON.	
L-ON	OFF in Dark state	Lights up when the output is ON.	

Note: LIGHT/BLINK switch is not related to the output operation selection.

7 BEAM ALIGNMENT

- Place the emitter and the receiver face to face along a straight line.
- After the cables have been correctly connected, switch the power ON.
- Move the emitter in the up, down, left and right directions, in order to determine the range of the beam received condition with the help of the operation indicator (orange) on the receiver. Then, set the emitter at the center of this range.
- Similarly, adjust for up, down, left and right angular movement of the emitter.
- Further, perform the angular adjustment for the receiver also.
- Interrupt each beam channel with the actual sensing object, and confirm that the sensor operates correctly.

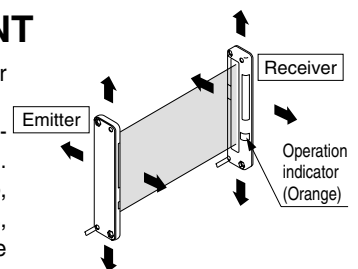

SUNX Limited

<http://www.sunx.co.jp/>

Head Office
 2431-1 Ushiyama-cho, Kasugai-shi, Aichi, 486-0901, Japan
 Phone: +81-(0)568-33-7211 FAX: +81-(0)568-33-2631
 Overseas Sales Dept.
 Phone: +81-(0)568-33-7861 FAX: +81-(0)568-33-8591

PRINTED IN JAPAN